

# **Easy Tool Retracting System SR2159**

**Metal Samples Company**

*A Division of Alabama Specialty Products, Inc.*

152 Metal Samples Rd., Munford, AL 36268 Phone: (256) 358-4202 Fax: (256) 358-4515

E-mail: [msc@alspi.com](mailto:msc@alspi.com) Internet: [www.metalsamples.com](http://www.metalsamples.com)

## **Mounting the Easy Tool**

*Refer to **Figure 1.***

1. Using the HANDLES move the SPINNER NUT assembly to the TOP most position.
2. Loosen the WING NUT and open the SWING ARM near the bottom of the Easy Tool.
3. Slide the Easy Tool onto the PROBE so that the PACKING BODY of the PROBE is held between the Easy Tool's MIDDLE PLATE and LOWER BASE.
4. Close the SWING ARM and tighten the WING NUT to secure the arm in place.
5. Move the INSERT SLIDE to the RETRACTED POSITION by pulling back on the KNOB. (See **Figure 2.**)
6. Turning the HANDLES on the SPINNER NUT, align the TOP LEG of the INSERT SLIDE to just above the SHOULDER OF THE CONNECTOR on the PROBE.
7. Push in the INSERT SLIDE to the ENGAGED POSITION, so that the TOP LEG rests on the SHOULDER OF THE CONNECTOR. (See **Figure 3.**)

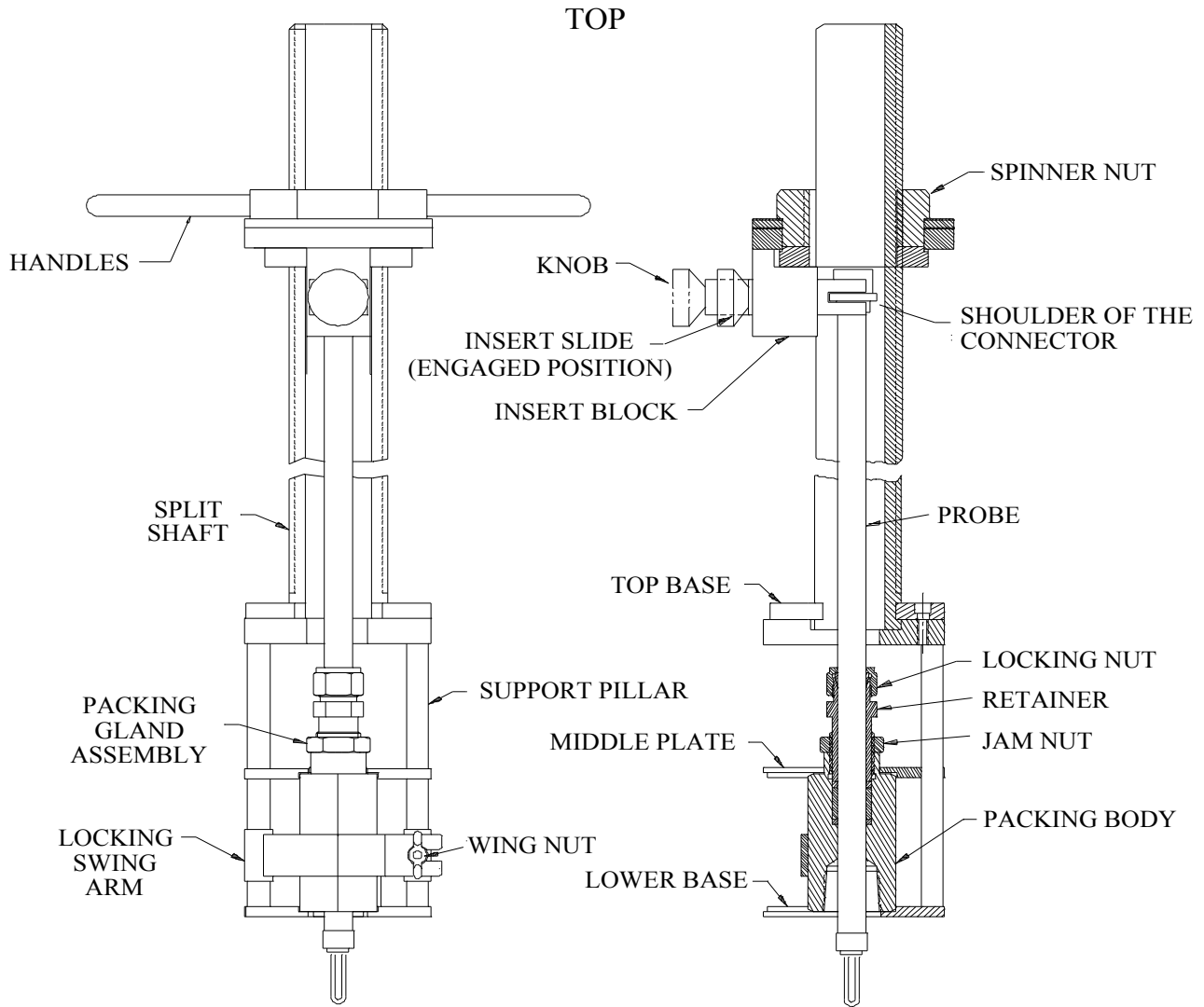

**Figure 1. Easy Tool Retracting System**

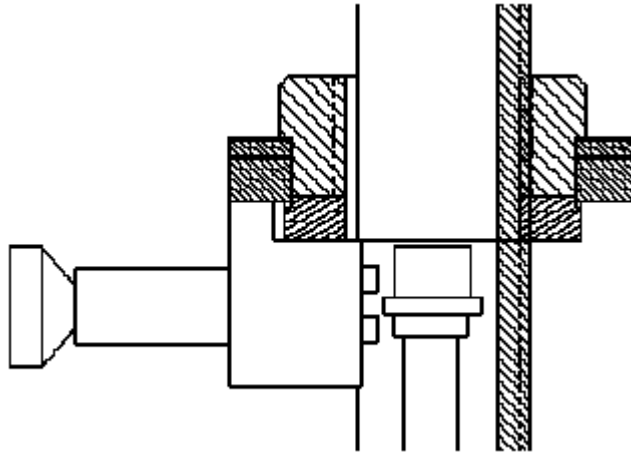

Figure 2. Insert Slide (Retracted Position)

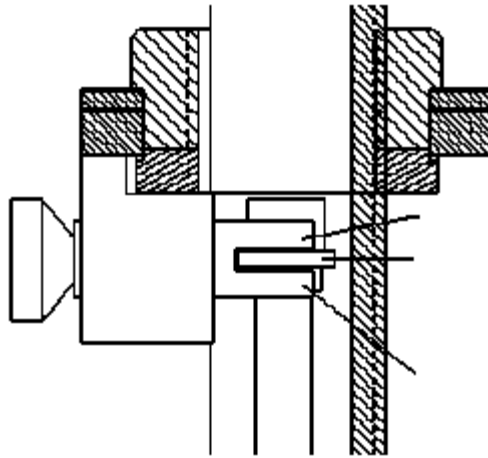

Figure 3. Insert Slide (Engaged Position)

## **Insertion**

1. Check to see if the RETAINER NUT on the PACKING BODY is tight, and adjust it as necessary. (See **Packing Gland Instructions.**)
2. Open the valve. If leakage occurs through the PACKING GLAND, tighten the RETAINER NUT. If leakage continues, close the valve, remove the PACKING GLAND from the system, and consult the FACTORY.
3. Tighten the JAM NUT on the PACKING BODY. (See **Packing Gland Instructions.**)
4. Insert the PROBE by turning the HANDLES on the SPINNER NUT clockwise until the PROBE reaches the desired depth. Insertion depth can be measured by using the scale on the Easy Tool.
5. Tighten the LOCKING NUT on the PACKING BODY. (See **Packing Gland Instructions.**)
6. Raise the SPINNER NUT until the BOTTOM LEG of the INSERT SLIDE is just below the SHOULDER OF THE PROBE CONNECTOR.

***CAUTION: IF THE PROBE MOVES OUTWARD AS THE SPINNER NUT IS RAISED, THE LOCKING NUT REQUIRES FURTHER TIGHTENING. IF AFTER FURTHER TIGHTENING THE PROBE CONTINUES TO MOVE OUTWARD, RETRACT THE PROBE FROM THE SYSTEM. ONCE THE PROBE HAS CLEARED THE VALVE, SHUT THE VALVE AND CALL THE FACTORY.***

7. Move the INSERT SLIDE to the RETRACTED POSITION. (See Figure 2.) Raise the SPINNER NUT until it clears the PROBE. Unlock the SWING ARM, and remove the Easy Tool from the PACKING BODY.

## **Retrieval**

1. Re-install the Easy Tool (refer to Mounting the Easy Tool).
2. Move the INSERT SLIDE to the ENGAGED POSITION so that the SHOULDER of the PROBE CONNECTOR is held by the INSERT SLIDE. (See Figure 3.)

***CAUTION: CONFIRM THAT THE INSERT SLIDE IS PROPERLY MOUNTED ON THE PROBE. IMPROPER MOUNTING OF THE EASY TOOL ON TO THE PROBE COULD RESULT IN UNCONTROLLED RELEASE OF THE PROBE.***

3. With the INSERT SLIDE properly mounted on the SHOULDER of the PROBE CONNECTOR, loosen the LOCKING NUT.
4. Retract the PROBE by turning the HANDLES on the SPINNER NUT counterclockwise until the PROBE has cleared the valve.
5. Once the PROBE has cleared the valve, close the valve. If the valve does not close, make sure the rod has been fully retracted.
6. If there is a bleed valve in place, open it to release pressure in the PACKING GLAND.
7. Move the INSERT SLIDE to the RETRACTED POSITION. (See Figure 2.) Raise the SPINNER NUT until it clears the PROBE. Unlock the SWING ARM and remove the Easy Tool.

***CAUTION: IF THE PROBE MOVES OUTWARD AS THE SPINNER NUT IS RAISED, MAKE SURE THE VALVE IS FULLY CLOSED AND THE PRESSURE IN THE NIPPLE HAS BEEN RELEASED.***

8. Remove the PACKING GLAND from the system.

**NOTE: Apply lubricating oil or grease on threaded and moving parts to prevent seizure of these components.**

## Packing Gland Instructions

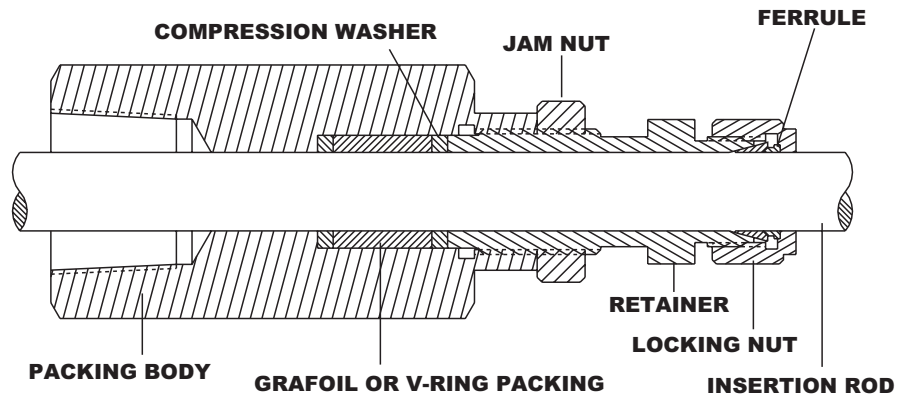
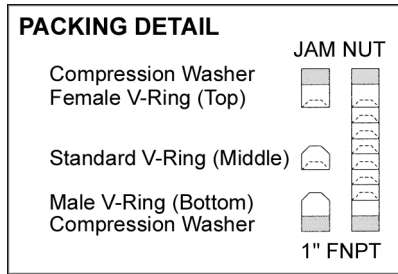

1. If PACKING GLAND is not already installed, slide the PACKING GLAND over the INSERTION ROD or PROBE.

**The packing must be adjusted prior to mounting packing gland to process.**

2. Loosen the LOCKING NUT. Slide LOCKING NUT and FERRULE away from the RETAINER.
3. Loosen the JAM NUT. Turn RETAINER clockwise to tighten the packing. The packing should be tightened until there is a resistance felt while sliding the INSERTION ROD in and out. The following table summarizes the recommended torque for ambient temperature against water:

Pressure Rating	150 psi	500 psi	1,000 psi	2,000 psi
PTE (Teflon®) Packing	240 in • lb 20 ft • lb	240 in • lb 20 ft • lb	300 in • lb 25 ft • lb	300 in • lb 25 ft • lb
Grafoil® Packing	180 in • lb 15 ft • lb	180 in • lb 15 ft • lb	240 in • lb 20 ft • lb	240 in • lb 20 ft • lb

**Do not over tighten packing. This will result in damage to the gland.**

4. Tighten the JAM NUT, thereby locking the RETAINER in place.
5. Mount the PACKING GLAND on the NIPPLE or FLANGE and secure in place. The rod should be fully retracted at this time with the LOCKING NUT and FERRULE clear of the RETAINER.

The following steps may require a certified pipe fitter for complete installation.

6. Open the process valve and check for packing leaks. If packing is leaking, shut the process valve, remove the PACKING GLAND, and readjust the PACKING GLAND using steps 3-5.

**The packing may be tightened as long as the rod will slide in and out of the gland.**

7. Insert to desired length. To lock the ROD in place, secure the LOCKING NUT and FERRULE.
8. Mount the safety plates or safety cap in place if applicable.

**Apply Anti-Seize Compound to prevent seizure of packing gland parts. "Chevrons" of Teflon® packing should be in the direction of open to process.**

*Packing Rings per Gland*

	3/8"	1/2"	5/8"
PTE (Teflon®) Packing	5	6	9
Grafoil® Packing	6	7	7

### Safety Notices

1. A SAFETY NUT or SHIELD must be installed on retractable probe(s) after inserting the PROBE into the PACKING GLAND and prior to mounting the PACKING GLAND in the process. If the SAFETY NUT or SHIELD is subjected to a sudden impact event, the probe must be inspected by qualified personnel prior to reinstallation.
2. If the system is greater than 150 psi, Metal Samples requires the use of an "Easy Tool Retracting System" to install and remove any retractable PACKING GLAND system and the use of a "Safety Clamp" once the retractable PACKING GLAND system has been installed.
3. All retractable PACKING GLAND components, especially safety devices, must be evaluated periodically for proper installation. Special care must be taken when evaluating components which are subject to high corrosion environments for structural integrity.

**Failure to follow the above safety measures can result in physical injury to personnel and/or damage to plant equipment. If there are any questions concerning these safety notices, please contact our offices prior to attempting to use these products.**

Teflon® is a registered trademark of DuPont.  
Grafoil® is a registered trademark of NeoGraf Solutions.