

MS2600E

High Resolution ER 4-20mA Transmitter

Operator's Manual



Metal Samples Company

A Division of Alabama Specialty Products, Inc.

152 Metal Samples Rd., Munford, AL 36268 Phone: (256) 358-4202 Fax: (256) 358-4515

E-mail: msc@alspi.com Internet: www.metalsamples.com

Table of Contents

- I. Introduction 2
 - A. General Description 2
 - B. Principles of Operation 2
 - C. Technical Specifications 4

- II. Installation and Operation 5
 - A. Receiving the MS2600E Transmitter 5
 - B. Installation 5
 - 1. Physical Mounting and Probe Connection 5
 - a. Direct-Probe Mounting 5
 - b. Remote Mounting 6
 - 2. Current Loop Connection 6
 - a. Making Connections 6
 - b. Grounding 7
 - c. Wiring for a Safe Area Installation 8
 - d. Wiring for a Hazardous Area Installation 8
 - 3. Setup and Operation 10
 - a. Probe Selection Switches 10
 - b. Testing the Current Loop 11
 - i. Calibration 11
 - ii. Testing loop output zero (4mA) and span (20mA) 11
 - iii. Testing the MS2600E with the Meter Prover 11
 - c. Interpreting Data 12
 - i. Metal Loss 12
 - ii. Calculating Corrosion Rate 12
 - d. Commissioning 14
 - C. Maintenance 14
 - D. Troubleshooting 15

- III. Service and Warranty Information 16
 - A. Warranty 16
 - B. Obtaining Service and Returning the Instrument for Repair 16
 - C. Instrument Repair Form 17

- Appendix A – Revision History 18

- Appendix B – Hazardous Area Certification Details 19

- Appendix C – Control Drawing (Hazardous Area Wiring Diagram) 23

I. Introduction

A. General Description

The MS2600E is a high-resolution meter designed to transmit corrosion (metal loss) data from an Electrical Resistance (ER) probe to a plant control system or other recording device. The MS2600E utilizes traditional 4-20mA current loop communication and is loop-powered, so it requires only a two-wire interface. This results in a simple and low-cost installation. The use of the 4-20mA protocol also allows the MS2600E to be placed great distances from the control system or recorder while maintaining good noise rejection. Practical current loop distances can be many thousands of feet (see pages 6 and 7 for exact specifications.)

The MS2600E is compatible with all types of Metal Samples ER probes, as well as any standard ER probe from other manufacturers. Unlike competitors' products, the MS2600E Transmitter does not require factory modification to accommodate different probe types. The probe type can be easily changed at any time using the on-board probe selection switches (see page 9.)

The MS2600E is available as direct-mount (standard) or remote-mount. In the direct-mount version the MS2600E is mounted directly to the ER probe. This option offers the simplest installation and minimizes noise problems. The remote-mount option allows the MS2600E to be mounted independently from (but in close proximity to) the ER probe. It is then connected to the probe via a short probe cable. (See page 5 for mounting diagrams and specifications.)

B. Principles of Operation

The MS2600E operates on the Electrical Resistance (ER) technique and is used in conjunction with an ER probe. The ER probe utilizes a resistive sensing element manufactured from the material of interest (or a close approximation) which is exposed to a corroding environment. This is called the Exposed or Corroding Element. The resistance of the Exposed Element is directly related to its thickness, so as the element corrodes the resulting loss of metal causes a proportional increase in the element's resistance. The probe also contains an internal Reference Element which is used to compensate for the influences of temperature on the Exposed Element.

The MS2600E is designed to work with any standard ER probe, but it is recommended that Cylindrical and Large Flush type probes be used to ensure optimum performance. Their physical design places the Reference Element in closer proximity to the Exposed Element compared to other probe types, providing more effective temperature compensation and thus reducing the effects of thermal noise.

Because they are designed to corrode, ER probes are sacrificial in nature. Each ER probe will have a finite life that is based on the element thickness. ER probes are available in a number of geometries and thicknesses designed to suit a wide variety of applications. Table 1 lists the common ER element options available from Metal Samples and the effective life of each.





Element Type		Compatibility	Thickness	Probe Life (Span)
	Tubular Loop	Compatible	4	2
			8	4
	Wire Loop	Compatible	40	10
			80	20
	Flush (Small)	Compatible	4	2
			8	4
			20	10
	Cylindrical	Preferred	10	5
			20	10
			50	25
	Flush (Large)	Preferred	5	2.5
			10	5
			20	10
			40	20

Table 1. Standard ER Probe Elements

The MS2600E measures an ER probe utilizing a high-resolution, 16-bit measurement. This allows the MS2600E to detect much smaller amounts of metal loss, thus responding faster to corrosion events and upsets (compared to traditional ER meters.) At 16-bit resolution the MS2600E can measure metal loss amounts as small as 0.0015% of the probe life.

Metal loss readings taken by the MS2600E are converted to a linearized 4-20mA current loop output. The 4-20mA signal can be fed into a plant control system or other devices and scaled accordingly to reflect metal loss. Then corrosion rates can be calculated based on the metal loss data over time. This is covered in more detail on pages 11 and 12. More information on ER probes, their theory, selection, and use can be found on our web site at <http://www.alspi.com/erintro.htm>.

C. Technical Specifications

Model MS2600E - High Resolution ER 4-20mA Transmitter

Physical Data

Instrument Weight:	3.70 lb. (1.68 Kg)
Total Weight w/ Accessories:	5.76 lb. (2.61 Kg)
Instrument Dimensions:	6.0"H x 4.0"Dia (15.25cm H x 10.16cm Dia)
Operating Temperature:	-40° to 158°F (-40° to 70°C)
Storage Temperature:	-40° to 176°F (-40° to 80°C)

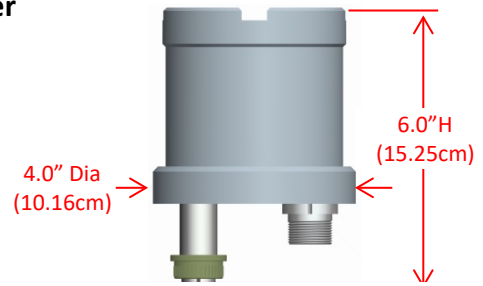

Figure 1. MS2600E Dimensions

Enclosure Material:	316 Stainless Steel
Mounting Specifications:	Direct probe mount (standard) May be pole mounted using optional hardware (Up to a 2.5" (6.35cm) Dia. pole)

Performance Data

Measurement Type:	ER measurement using any standard ER probe type (Wire Loop, Tube Loop, Cylindrical, Flush, Strip, etc.)
Range:	0-100% of probe life
Resolution:	0.0015% of Probe Life (16-bit)
Cycle Time:	1 Minute

Electrical Data

Power Requirements:	11 to 28 VDC
Nominal Probe Cable Distance:	30 ft (9.1 m)
Output Specifications:	4-20mA Current Loop Output

Hazardous Location Certifications

Europe and Worldwide (ATEX and IECEx)	II 1 G Ex ia IIC T4 Ga - 40°C ≤ Tamb ≤ + 70°C Ex ia IIC T4 Ga - 40°C ≤ Tamb ≤ + 70°C
--	---

ATEX Certificate No: **ITS14ATEX27981X**
IECEx Certificate No: **IECEx ITS 14.0010X**

USA and Canada (ETL)	Ex ia IIC T4 Ga Class I, Division 1, Groups A, B, C & D, T4 Class I, Zone0, AEx ia IIC T4 Ga -40° C ≤ Ta ≤ +70° C
-------------------------	--

Included Accessories

33' (10 meters) Current Loop Wiring Harness (provided to facilitate wiring to a nearby junction box, can be cut to length if required), Meter Prover, Operations Manual

Optional Accessories

Probe Extension Cable, Remote Mounting Hardware

II. Installation and Operation

A. Receiving the MS2600E Transmitter

Check the MS2600E Transmitter for any shipping damage when it is first received. When the MS2600E is unpacked, verify that the following items are included:

- MS2600E Transmitter
- Current Loop Wiring Harness
- Meter Prover
- User's Manual
- Probe Cable (optional, for remote-mount only)
- Mounting Hardware (optional, for remote-mount only)

In the event of shipping damage, quantity shortage, or missing items, it is recommended that the event is documented immediately and that digital photographs are taken. Any shortages or missing items should be reported to Metal Samples immediately. In the event of shipping damage, a claim should be opened with the responsible carrier.

B. Installation

CAUTION: *Using this product in any way other than that specified within this manual may impair the intrinsic safety protection.*

ATTENTION: *L'utilisation de ce produit d'une manière autre que celle spécifiée dans ce manuel peut altérer la protection de sécurité intrinsèque.*

Installation of the MS2600E Transmitter involves the following steps:

1. Physical Mounting
2. Electrical Connection
3. Setup and Programming

1. Physical Mounting and Probe Connection

Warning: *Disconnect power and probe connections before opening the enclosure. Refer user manual for installation instructions and maximum electrical input & output parameters.*

Avertissement: *Débranchez les connexions d'alimentation et de sonde avant d'ouvrir le boîtier. Reportez-vous au manuel de l'utilisateur pour les instructions d'installation et les paramètres d'entrée et de sortie électriques maximum.*

When selecting a location to mount the MS2600E it is important to consider the surrounding environment. To ensure proper operation:

- Do not mount the MS2600E in a location that exceeds its operating temperature.
- Avoid mounting the MS2600E near sources of strong electrical noise.
- Ensure that there is sufficient clearance for installation and to open the transmitter cover afterwards.

a. Direct-Probe Mounting

The MS2600E is designed for direct-probe mounting which eliminates the need for additional hardware and transmitter-to-probe cabling. This greatly simplifies installation, reduces costs, and minimizes electrical noise that can be coupled onto probe cabling from nearby electrical equipment.

Before mounting the MS2600E, first ensure that the probe is installed properly and securely. During installation it is important that you do not apply excessive force on the probe or seals, as doing so could break the seal and result in system leakage.

To mount the MS2600E:

1. Align the keyways of the transmitter and probe connectors.
2. Insert the transmitter connector plug fully into the probe connector receptacle.
3. Secure the transmitter to the top of the probe by tightening the coupling nut.

NOTE: Hand-tight is sufficient. Do not over-tighten the coupling nut.

NOTE: Never force the connectors to mate. If there is resistance, stop and check for bent pins on the probe and for foreign material in the female sockets of the transmitter connector. Gently straighten any bent pins and clear any foreign material that may be found.

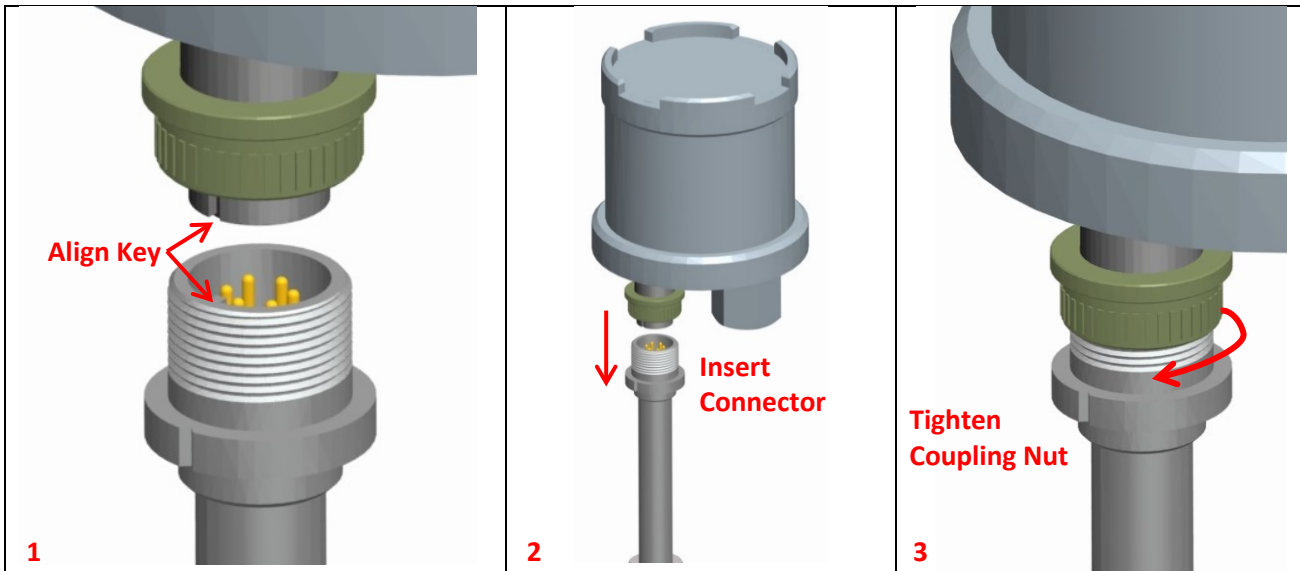

Figure 2. MS2600E Direct Mount Installation

b. Remote Mounting

When it is not practical to direct-probe mount the MS2600E, the unit can be remote mounted instead. In this case the instrument is mounted to a separate mounting pole using the optional Remote Mounting Hardware Kit. The MS2600E is then connected to the ER probe via the optional probe extension cable. When possible, the MS2600E should be mounted within 10' (3m) of the probe to keep the probe cabling short and minimize signal degradation.

2. Current Loop Connection

a. Making Connections

The MS2600E current loop connection is made via the external 6-pin circular connector as shown below. This hermetically sealed connector prevents moisture ingress, and eliminates the need for internal wiring by an operator which reduces the risk of damage to the circuit.

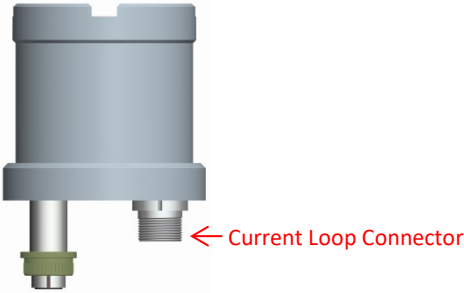

Figure 3. MS2600E Current Loop Connector

To facilitate wiring, a thirty-three foot (10 meter) Current Loop Wiring Harness is provided. This wiring harness connects directly to the 6-pin connector, and extends to a nearby junction box (not included) to make the necessary wiring connections to the current loop wiring from the control (DCS/SCADA) system. The wiring harness can be cut to length if required.

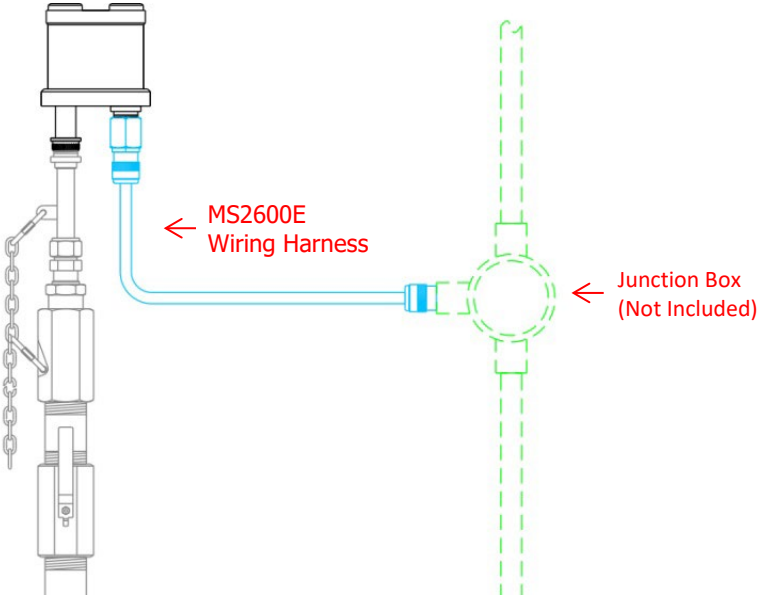

Figure 4. MS2600E Wiring Harness

NOTE: Do not connect cable shielding to the Transmitter. The shield must remain floating at the Transmitter.

The maximum permissible length of the current loop wiring between the MS2600E Transmitter and the control system is determined by the control system supply voltage, the electrical resistance of the current loop cable and the load of the control system input. If the Transmitter is to be installed in a

safe area, refer to section c. *Wiring for a Safe Area Installation* for details. If the Transmitter is to be installed in a hazardous area, refer to section d. *Wiring for a Hazardous Area Installation*.

b. Grounding

The MS2600E enclosure is grounded internally through the wiring harness, but an additional, external grounding terminal is provided as well. The enclosure should be grounded properly using the external grounding terminal to ensure safe operation.

c. Wiring for a Safe Area Installation

CAUTION: When used in non-hazardous areas, equipment must be supplied with a pre-approved power supply unit or approved equipment with the following maximum input parameters.

ATTENTION: Lorsqu'il est utilisé dans des zones non dangereuses, l'équipement doit être fourni avec un bloc d'alimentation pré-approuvé ou un équipement approuvé avec les paramètres d'entrée maximum suivants.

$$U_i = 28 \text{ V, } I_i = 93 \text{ mA and } P_i = 0.65 \text{ W}$$

The pre-approved equipment must be certified to the electrical safety standards for equipment in ordinary location. For Example EN/IEC/CSA UL 61010-1, EN/IEC/CSA UL 60950-1 etc...,

For basic safe area wiring information refer to the circuit diagram shown on page 19. Use the following equation to determine maximum permissible cable length:

$$D = \frac{(V_s - 10)}{(4 * 10^{-5})(R)}$$

Where:

D = Max. cable length in feet.

V_s = Power supply voltage.

R = Cable resistance in ohms per 1000 feet.

Example:

VS = 24 Volts

R = 16.1 (22 AWG cable)

$$D = \frac{(24 - 10)}{(4 * 10^{-5})(16.1)} = 21,739 \text{ Feet}$$

d. Wiring for a Hazardous Area Installation

CAUTION: This section provides general guidelines for hazardous area wiring. However, regardless of anything stated here, the MS2600E must be installed in full compliance with the control drawing located on page 18 and all of the local area requirements.

ATTENTION: Cette section fournit des directives générales pour le câblage en zone dangereuse. Cependant, indépendamment de tout ce qui est indiqué ici, le MS2600E doit être installé en totale conformité avec le schéma de contrôle situé à la page 18 et toutes les exigences locales

CAUTION: When used in Hazardous areas, equipment must be supplied with a pre-approved power supply unit or approved equipment via a certified intrinsically safe barrier or a galvanically isolated barrier) with the following maximum input parameters.

ATTENTION: Lorsqu'il est utilisé dans des zones dangereuses, l'équipement doit être fourni avec un bloc d'alimentation pré-approuvé ou un équipement approuvé via une barrière de sécurité intrinsèque certifiée ou une barrière isolée galvaniquement) avec les paramètres d'entrée maximum suivants
 $U_i = 28\text{ V}$, $I_i = 93\text{ mA}$ and $P_i = 0.65\text{ W}$

Whenever an electrically driven sensor or measuring device is used in a potentially explosive environment the measuring system must be installed in such a way that electrical energy is either effectively isolated from the explosive environment (via explosive-proof containers, cable conduits, etc.) or the amount of electrical energy produced in the hazardous area must be limited to an intrinsically safe level.

Limiting electrical energy is the most practical method of protecting the MS2600E measuring system when the Transmitter is installed in a hazardous area. In the MS2600E system, electrical energy limits are maintained by the use of a repeater safety barrier (or its equivalent) installed in the 4-20 mA current loop per standard practice. The safety barrier must be located in the safe area near the boundary between the safe and hazardous areas. The safety barrier will repeat the signal current generated by the Transmitter and will relay the signal to the data receiving station.

Caution: When a safety barrier is used with the MS2600E system, the current loop cable must be connected to the barrier's hazardous area terminals. All other connections must be made to the barrier's safe area terminals.

The type of repeater safety barrier employed in the MS2600E system depends on the specific classification of the hazardous environment in question. Metal Samples will provide, upon request, assistance and technical advice in the selection of a repeater safety barrier or its equivalent.

For most installations, Metal Samples recommends the intrinsically safe MTL 5441 Repeater Power Supply.

The maximum length of the current loop cable that connects the MS2600E Transmitter to the repeater safety barrier is as follows:

Example:

17.5 Volts
22 AWG Cable = 5,434 feet maximum
16 AWG Cable = 21,788 feet maximum

CAUTION: For hazardous area installations, the maximum inductance and capacitance of the loop wiring between the safety barrier and the transmitter cannot exceed the entity parameters of the selected barrier.

ATTENTION: Pour les installations en zone dangereuse, l'inductance et la capacité maximales du câblage de la boucle entre la barrière de sécurité et le transmetteur ne peuvent pas dépasser les paramètres d'entité de la barrière sélectionnée.

3. Setup and Operation

a. Probe Selection Switches

Housed within the MS2600E enclosure are probe selection switches which allow the instrument to be set for any standard ER probe type. They also allow the instrument to be placed into several test modes which output fixed values, allowing verification of the current loop connection and DCS program.

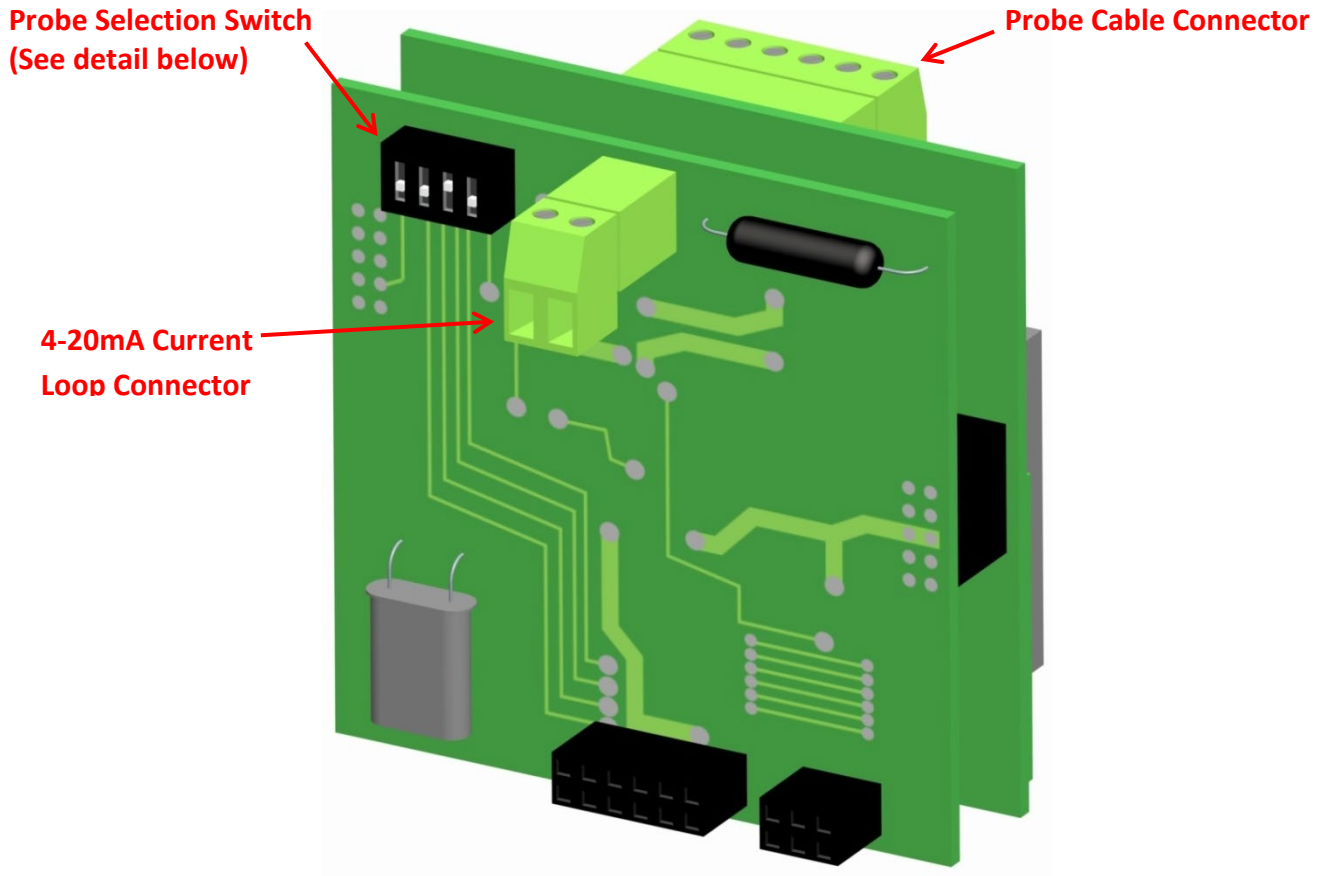

Figure 5. Connector and Switch Details

		Setting	Switch 1	Switch 2	Switch 3	Switch 4
Operating Positions	Wire Loop		Off (↓)	On (↑)	On (↑)	Off (↓)
	Tube Loop/Flush		On (↑)	Off (↓)	On (↑)	Off (↓)
	Cylindrical*		Off (↓)	Off (↓)	On (↑)	Off (↓)
Test Positions	4mA Output		On (↑)	On (↑)	Off (↓)	Off (↓)
	20mA Output		Off (↓)	On (↑)	Off (↓)	Off (↓)
	4-20mA Sweep		On (↑)	Off (↓)	Off (↓)	Off (↓)

Table 2. Probe Switch Settings

*Cylindrical probe setting is illustrated.

b. Testing the Current Loop

i. Calibration

The MS2600E is fully calibrated when shipped from the factory. The calibration settings are fixed to avoid accidental change which could result in erroneous data. No field calibration is required. However, it is important to test the MS2600E upon installation, and during periodic maintenance inspections, to ensure the unit is operating properly.

ii. Testing loop output zero (4mA) and span (20mA)

The MS2600E Probe Selection Switches (page 9) offer three test settings that allow the unit to be placed into various diagnostic modes as follows:

- 1) 4mA Output – Forces a constant 4mA output on the current loop.
- 2) 20mA Output – Forces a constant 20mA output on the current loop.
- 3) 4-20mA Sweep – Causes the output to continually cycle from 4mA up to 20mA.

These test modes can be useful when troubleshooting problems with the current loop wiring and DCS/SCADA system.

iii. Testing the MS2600E with the Meter Prover

A Meter Prover is provided to allow routine checks of the MS2600E. The Meter Prover simulates a Wire Loop type probe at a fixed value. To test the MS2600E with the Meter Prover:

- 1) Disconnect power.
- 2) Disconnect the MS2600E from the probe (or if the MS2600E is remote-mounted, disconnect the probe extension cable from the probe.)
- 3) Connect the Meter Prover to the MS2600E probe connector stem (or to the probe extension cable if the MS2600E is remote-mounted.)
- 4) Loosen the MS2600E Enclosure Lock Screw.
- 5) Unthread and remove the MS2600E cover.
- 6) Change the Probe Selection Switches to the Wire Loop position (see page 9.)
- 7) Reconnect power and allow the instrument to measure for several minutes to stabilize.
- 8) After several minutes observe the transmitter output. The output should closely match the value printed on the Meter Prover label.

If the transmitter output matches the Meter Prover value, you may return the Probe Selection Switches to their previous setting and reconnect the MS2600E to the probe. If the transmitter output shows a significant difference compared to the Meter Prover value, further troubleshooting may be required. Refer to page 14 for troubleshooting or contact the factory for further assistance.

Be sure to reinstall the enclosure cover and tighten the Lock Screw when putting the MS2600E back into service.

c. Interpreting Data

i. Metal Loss

The MS2600E measures the Metal Loss of an ER probe and converts that value to a linearized 4-20mA current loop output. The 4-20mA output is directly proportional to the cumulative Metal Loss of the ER probe at any given time. The overall span of the 4-20mA output is proportional to the life of the probe in use, so for DCS/SCADA programming the 4-20mA signal can be scaled as follows:

4mA = 0 mils (0% Metal Loss)

20mA = Probe Life in mils (100% Metal Loss)

The Probe Life can be found in Table 1 and is also listed on the Metal Samples probe tag (as the "Multiplier".)

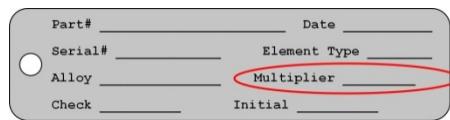

Figure 6. Metal Samples Probe Tag

Figure 7 illustrates the relationship between Loop Current and Metal Loss. In this example a probe with a 10-mil life is assumed. However, the X axis could be changed to represent any Probe Life.

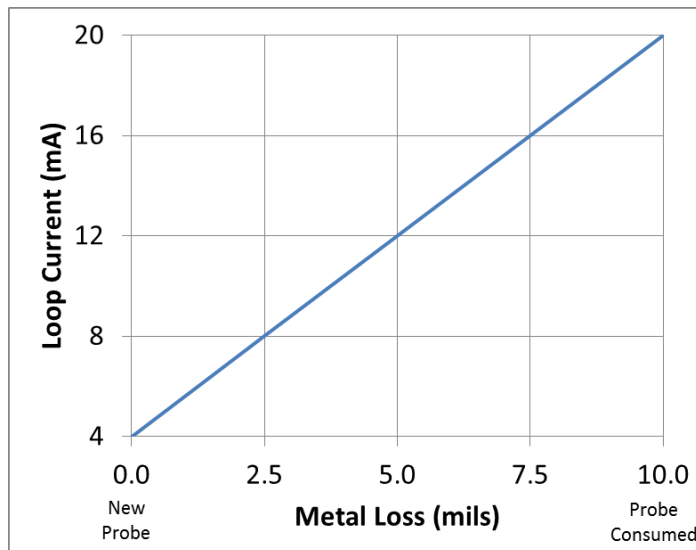

Figure 7. Output Relationship

As seen here, the transmitter output begins at 4mA for a new probe (zero Metal Loss) and increases as the probe element corrodes, eventually reaching a maximum of 20mA when the probe sensing element has been completely consumed by corrosion (in this case, 10 mils of Metal Loss.) At this time the probe has reached its end-of-life and must be replaced.

ii. Calculating Corrosion Rate

As explained previously, ER probes and instruments report *Metal Loss*. However, the value that is of

ultimate interest is Corrosion Rate. The Corrosion Rate is essentially Metal Loss over time, so the Corrosion Rate can be calculated using the following formula:

$$\text{Corrosion Rate(mpy)} = \frac{\Delta\text{Loop Current(mA)}}{16} \times \frac{365}{\Delta\text{Time(days)}} \times \text{Probe Life(mils)}$$

where:

$\Delta\text{Loop Current(mA)}$ is the difference between two readings

$\Delta\text{Time(days)}$ is the time difference between those two readings

It is a common practice to program this formula into the control (DCS/SCADA) system and have it calculate Corrosion Rate on a continual basis from the Metal Loss data. The challenge in doing this is selecting an appropriate time interval. Using an interval that is too short may give erratic results, while selecting an interval that is too long may give results that are insensitive to system upsets. The ideal time period depends on many factors, and will vary from system to system. It may take some trial and error to settle on the best time period for your installation.

In some cases it may be necessary to review the raw Metal Loss data and manually apply the Corrosion Rate formula to periods of interest. For example, look at the graph below and see how much the calculated Corrosion Rate can vary depending on the time period used.

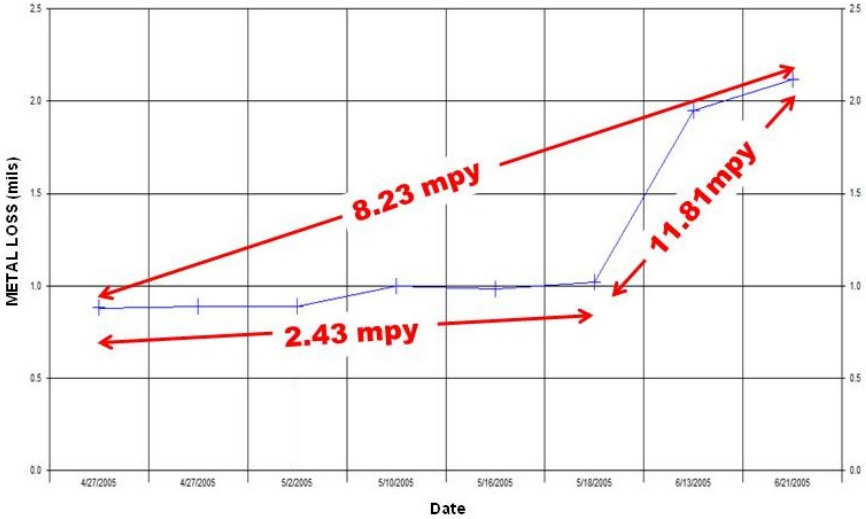

Figure 8. Corrosion Rates calculated from Metal Loss data

While each of the results is valid for the selected time period, the one of most interest is the value of 11.81 mpy which represents some type of system upset. When the Corrosion Rate is calculated automatically on a pre-selected time period, there is no guarantee that the selected time period will always coincide with system upsets such as this. That is why manual review and interpretation of Metal Loss data is also helpful.

d. Commissioning

Once the MS2600E has been installed, tested, and properly configured for the probe in use, it can then be closed and put into service. First, perform one last visual inspection to ensure that all electrical connections are secure, and that the enclosure o-ring is in place and is in good condition. Then thread the enclosure lid onto the base fully. Once the lid has been threaded into place, tighten the Lock Screw to prevent unauthorized tampering.

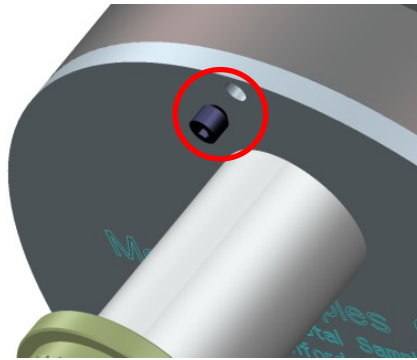

Figure 9. Enclosure Lock Screw

CAUTION: The Lock Screw on the instrument base must be tightened securely to prevent unauthorized personnel from opening the MS2600E, and ensure that the intrinsic safety is not violated. Only qualified personnel should be allowed to install, operate, and maintenance the MS2600E.

C. Maintenance

Once installed, the MS2600E requires little maintenance. However, it is important to verify the following items periodically to ensure continued safe operation.

CAUTION: Before performing any tests or maintenance on the MS2600E, ensure that all hazardous area requirements are met.

Inspection Item	Frequency
Inspect the enclosure o-ring for any signs of damage. Replace as necessary.	Annually
Inspect the probe connector o-ring for any signs of damage. Replace as necessary.	Annually
Inspect the external electrical connections for signs of corrosion, mechanical damage, or foreign matter that could cause damage or cause an electrical short. Clean as necessary.	Annually
Ensure that the locking screw is in place and is secure	Annually
The MS2600E enclosure is made of corrosion-resistant 316 stainless steel. However, it should still be checked periodically for any signs of corrosion.	Annually
Check for any signs of moisture ingress within the enclosure.	Annually

Contact Metal Samples for replacement parts or if instrument repair is necessary.

D. Troubleshooting

If the MS2600E does not seem to perform as expected, check the following items:

CAUTION: Before performing any tests or maintenance on the MS2600E, ensure that all hazardous area requirements are met.

1. Ensure that the probe is operational and is not completely corroded. This can be done in two ways.
 - a. Test the probe with a portable ER meter if available.
 - b. Test the probe with a portable resistance or continuity meter as follows:
 - i. Connect one test lead to pin 'A' of the probes 6-pin connector.
 - ii. Measure continuity to each of the other pins. There should be continuity (low resistance) to each pin.

NOTE: Continuity on each pin does not ensure that the probe is good. However, if you find an open circuit on any pins then it is almost certain that the probe is bad and should be replaced.

2. Ensure that the Probe Selection Switches are set correctly for the probe being used. Confirm the probe type, and refer to Table 2 on page 9 to verify the appropriate switch settings.
3. Perform a visual inspection of the circuit boards to look for any signs of mechanical or electrical damage.
4. Ensure that all electrical cables and wiring are in good condition.
5. Ensure that all electrical contacts are secure and free of corrosion.
6. Ensure that there is adequate supply voltage at the 4-20mA Current Loop Connector.
7. Verify that the supply voltage polarity is correct.
8. If there is insufficient supply voltage on the 4-20mA Current Loop Connector, check the safety barrier (if applicable) for a blown fuse or any other failure.
9. Test the MS2600E using the supplied Meter Prover (see page 10.)
10. Test the MS2600E with a local multi-meter or loop calibrator.

These basic checks should indicate the source of any problem (probe, power supply, wiring, etc...) If it is determined that the MS2600E is malfunctioning, or if you need further assistance in troubleshooting, contact Metal Samples Technical Support.

CAUTION: If the MS2600E shows any signs of damage remove it from service immediately and consult the factory.

III. Service and Warranty Information

A. Warranty

Metal Samples warrants that any part of the MS2600E and accessories which proves to be defective in material or workmanship within one year of the date of original shipment to Purchaser will be repaired or replaced, at Metal Samples option, free of charge. This warranty does not cover (1) probe assemblies, (2) items expendable in nature, or (3) items subject to damage from normal wear, misuse or abuse, or failure to follow use and care instructions.

All damaged items are to be shipped at Purchaser's expense to and from Metal Samples which shall have the right to final determination as to the existence and cause of a defect.

The foregoing shall constitute the sole and exclusive remedy of any purchaser of Metal Samples products for breach of warranty and IS EXCLUSIVE AND IN LIEU OF ALL OTHER WARRANTIES, EXPRESSED, IMPLIED OR STATUTORY, INCLUDING THE IMPLIED WARRANTIES OR MERCHANTABILITY AND FITNESS. IN NO EVENT SHALL METAL SAMPLES BE LIABLE FOR SPECIAL OR CONSEQUENTIAL DAMAGES, OR FOR ANY DELAY IN THE PERFORMANCE OF THIS WARRANTY DUE TO CAUSES BEYOND ITS CONTROL.

The technical information and suggestions contained herein are believed to be reliable, but they are not to be construed as warranties since conditions of use are beyond our control.

B. Obtaining Service and Returning the Instrument for Repair

If you experience problems with your instrument please contact the factory at 256-358-4202 and ask for customer support for instrumentation. Our customer support department will assist you in troubleshooting your instrument.

Most issues can be resolved over the phone, but in some cases it may be necessary to return your instrument for further evaluation and repair. In this case, please obtain a Return Materials Authorization (RMA) number from the sales person or support technician. This RMA number will ensure that your instrument is routed to the correct department when it is received at the factory.

After receipt of an RMA number you may pack your instrument for return. Be sure to pack your instrument in a sturdy box and to pad it sufficiently to avoid damage during transit. Also be sure to complete the "Instrument Repair Form" on the next page and include a copy with your repair. This will ensure that the repair department has sufficient information regarding the problems you are experiencing with your instrument, as well as the billing, contact, and return shipping details for the repair.

Once you have obtained an RMA number, completed the "Instrument Repair Form", and packed your instrument securely, please ship it prepaid to the following address:

Metal Samples
152 Metal Samples Road
Munford, AL 36268
ATTN: RMA# _ _ _ _ _

NOTE: Be sure to list your RMA number in the attention line (shown as blanks in the example above.)

C. Instrument Repair Form

This form may be photocopied for use when returning an instrument to Metal Samples for repair. Please fill in all known information and enclose a copy of the completed form with the instrument.

General Information

Model Number		Serial Number	
RMA Number		Date of Purchase*	

**If known.*

Contact Information for Repair

Contact Name		Company	
Phone Number		E-mail Address	

Return Shipping Information

Recipient Name*		Company*	
------------------------	--	-----------------	--

Return Address	

**If different than above.*

Reason for Return. (Provide as much detail as possible. Attach additional pages if required.)

Invoice Instructions (For non-warranty repairs)

<input type="checkbox"/>	Invoice me for the repair <i>(Requires an open account with Metal samples.)</i>	→	Reference PO#	
<input type="checkbox"/>	Contact me for credit card information <i>(For security purposes, do not list credit card information on this form..)</i>			

Appendix B: Hazardous Area Certification Details

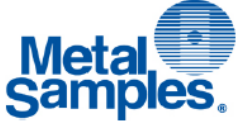
	MS26X0E & MS29X0E Hazardous Area Certification Details	Doc.Number	EXDOC-000019
		Revision	0
		Date	04/15/2020
		Page	1 of 2
Worldwide and Europe		Ex ia [ia] IIC T4 Ga $-40^{\circ}\text{C} \leq \text{Ta} \leq +70^{\circ}\text{C}$ ATEX Cert. No: ITS ATEX 27981X IECEx Cert. No: IECEx ITS 14.0010X X – See special Conditions below	
USA AND CANADA		Class I, Zone 0, AEx ia IIC T4 Ga Class I, Division 1, Groups A, B, C & D, T4	
<u>Hazardous Area Installation</u>			
<p>CAUTION: This section provides general guidelines for hazardous area wiring. However, regardless of anything stated here, the MS26X0E / MS29X0E ER transmitter must be installed in full compliance with the control drawing provided Annexure-C and all of the local area requirements.</p>			
<u>Entity Parameters</u>			
<u>at Probe (common for all models)</u>			
Uo:	4.94V		
Io:	66.2 mA		
Po:	0.328W		
Co:	0.4μF		
Lo:	70μH		
<p>1 When used in Hazardous areas, equipment must be supplied with pre-approved power supply or approved equipment via certified intrinsically safe barrier or galvanically isolated barrier with the following maximum input parameters</p>			
<p>Ui = 28V , li = 93mA and Pi = 0.65 W</p>			

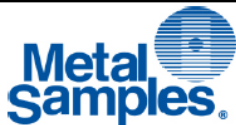

MS26X0E & MS29X0E Hazardous Area
Certification Details

Doc.Number	EXDOC-000019
Revision	0
Date	04/15/2020
Page	2 of 2

Special Conditions

- 1 When installed in a Zone 0 potentially explosive atmosphere requiring EPL Ga apparatus, the equipment shall be installed such that even in the event of rare incidents, an ignition source due to impact or friction between the aluminum alloys parts of the enclosure are excluded.

Caution

- 1 When used in non- hazardous areas, equipment must be supplied with pre-approver power supply or approved equipment with the following maximum input parameters

$$U_i = 28V, I_i = 93mA \text{ and } P_i = 0.65 W$$

- 2 The Lock Screw on the instrument base must be tightened securely to prevent opening the MS26X0E / MS29X0E, and ensure that the intrinsic safety is not violated. Only qualified personnel should be allowed to install, operate, and maintenance the MS26X0E / MS29X0E.

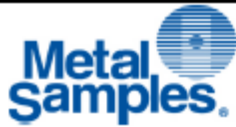

Détails de la certification MS26X0E et MS29X0E
pour zones dangereuses

Doc.Number	EXDOC-000023
Revision	0
Date	4/15/2020
Page	1 of 2

MONDE ET EUROPE

Ex ia [ia] IIC T4 Ga
-40°C ≤ Ta ≤ +70°C

ATEX Cert. No: ITS ATEX 27981X
IECEX Cert. No: IECEx ITS 14.0010X
X - Voir les conditions particulières ci-dessous

USA ET CANADA

Class I, Zone 0, AEx ia IIC T4 Ga
Class I, Division 1, Groups A, B, C & D, T4

Installation en zone dangereuse

ATTENTION : Cette section fournit des directives générales pour le câblage en zone dangereuse. Cependant, indépendamment de tout ce qui est indiqué ici, le transmetteur MS26X0E / MS29X0E ER doit être installé en totale conformité avec le schéma de contrôle fourni en Annexe-C et toutes les exigences locales.

Paramètres d'entité

at Probe (commun à tous les modèles)

Uo: 4.94V
Io: 66.2 mA
Po: 0.328W
Co: 0.4µF
Lo: 70µH

- 1 Lorsqu'il est utilisé dans des zones dangereuses, l'équipement doit être fourni avec une alimentation pré-approuvée Fourniture ou équipement approuvé via une barrière certifiée à sécurité intrinsèque ou par voie galvanique barrière isolée avec les paramètres d'entrée maximum suivants

Ui = 28V , li = 93mA and Pi = 0.65 W

Conditions spéciales

- 1 Lorsqu'il est installé dans une atmosphère potentiellement explosive de zone 0 nécessitant un appareil EPL Ga, l'équipement doit être installé de telle sorte que même en cas d'incidents rares, une source d'inflammation en raison de chocs ou de frottements entre les alliages d'aluminium, les parties du boîtier sont exclues.

Mise en garde

- 1 Lorsqu'il est utilisé dans des zones non dangereuses, l'équipement doit être alimenté au préalable Fournir ou équipement approuvé avec les paramètres d'entrée maximum suivants

$U_i = 28V$, $I_i = 93mA$ and $P_i = 0.65 W$

- 2 La vis de verrouillage sur la base de l'instrument doit être fermement serrée pour empêcher l'ouverture du MS26X0E / MS29X0E et assurez-vous que la sécurité intrinsèque n'est pas violée. Seulement qualifié le personnel doit être autorisé à installer, utiliser et entretenir le MS26X0E / MS29X0E

Appendix C: Drawings

Wiring Diagrams

Control Drawing (Hazardous Area Wiring Diagram)

HAZARDOUS AREA

SAFE AREA

MS2600E/MS2650E/MS2900E/MS2950E HIGH RESOLUTION ER 4-20mA TRANSMITTER

NOTE: INSTALLATION OF MS2600E/MS2650E/MS2900E/MS2950E 2-WIRE ER TRANSMITTER IN GROUP IIC HAZARDOUS LOCATIONS.

MAXIMUM OUTPUT ENTITY PARAMETERS AT CN2 - PROBE TERMINALS
 $U_D = 4.94 \text{ Vdc}$
 $I_D = 66.2 \text{ mA}$
 $P_D = 0.328 \text{ W}$

CN1 - INPUT TERMINAL
 $U_i = 28.0 \text{ Vdc}$
 $I_i = 0.093 \text{ A}$
 $P_i = 0.65 \text{ W}$
 $C_i = 50.42 \text{ nF}$
 $L_i = 27.53 \text{ nH}$

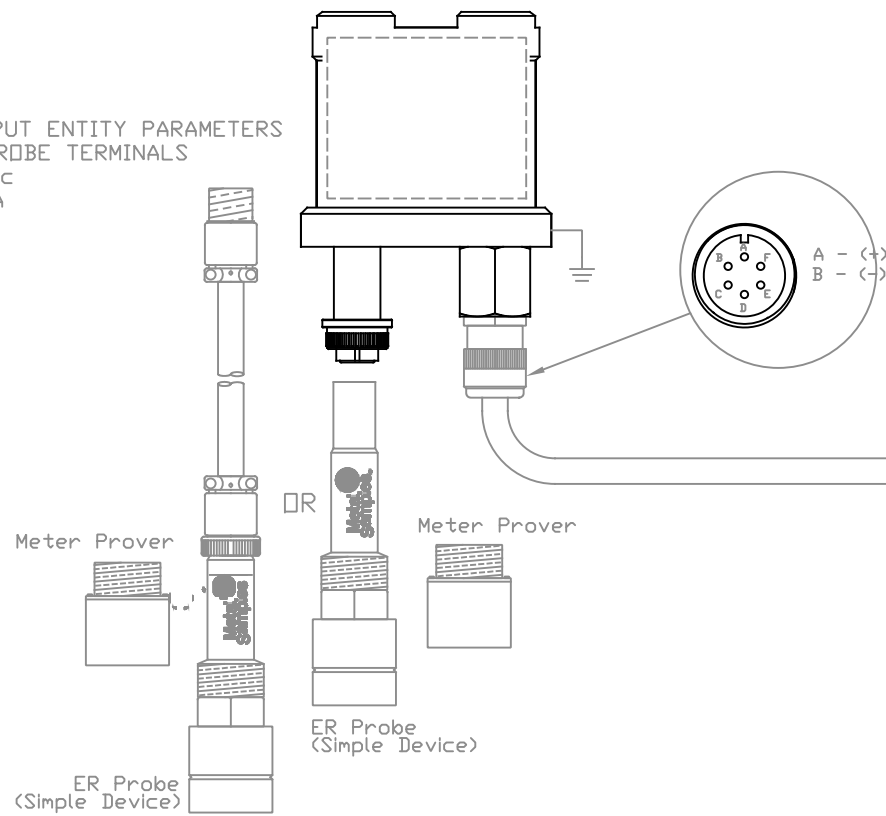

CERTIFIED SAFETY BARRIER (EEx ia) IIC
 $U_o = 28\text{V}$, $I_o = 93\text{mA}$, $P_o = 650\text{mW}$
 TYPICAL OF MTL 7787+ Equivalent

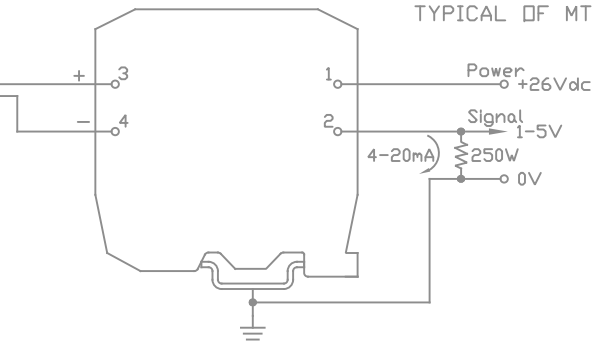

MS2600E/MS2650E/MS2900E/MS2950E HIGH RESOLUTION ER 4-20mA TRANSMITTER

MAXIMUM OUTPUT ENTITY PARAMETERS AT CN2 - PROBE TERMINALS
 $U_D = 4.94 \text{ Vdc}$
 $I_D = 66.2 \text{ mA}$
 $P_D = 0.328 \text{ W}$

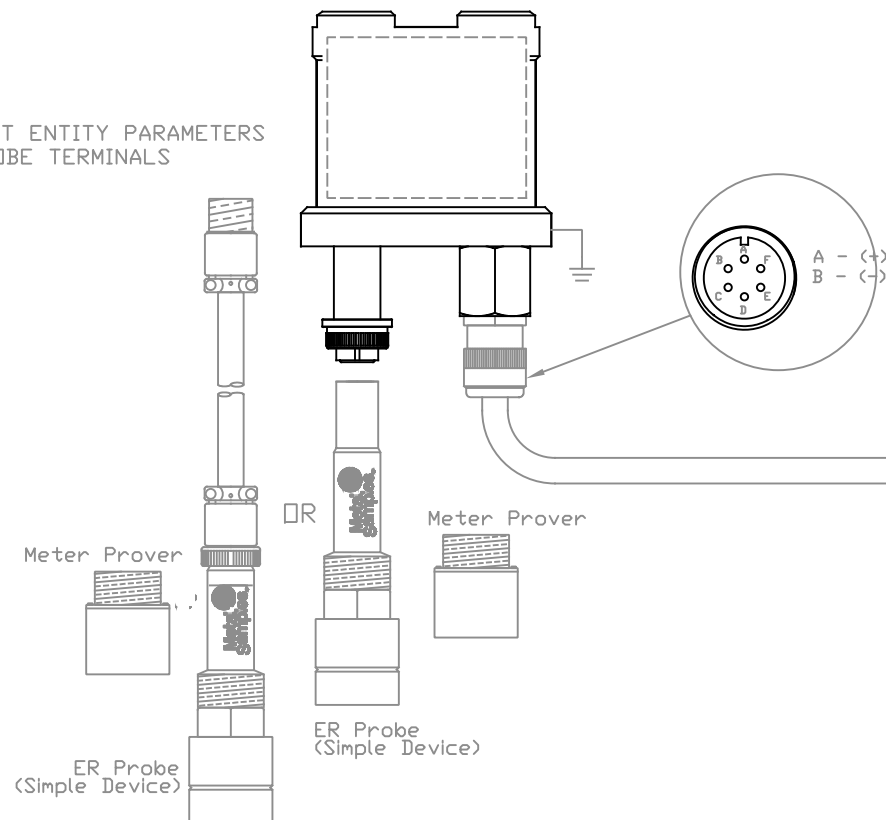

CERTIFIED 4-20mA REPEATER POWER SUPPLY (EEx ia) IIC
 $V_o = 28\text{V}$, $I_o = 93\text{mA}$, $P_o = 651\text{mW}$
 TYPICAL OF MTL 5541 or Equivalent

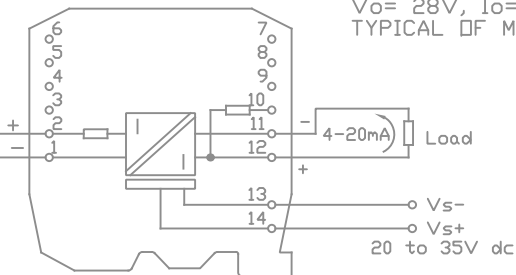

REV	DATE	DESCRIPTION	BY	CHKD
B	04/15/20	NEW MODELS INCLUDED IN DRAWING	BP	
A	6/25/14	ADDED PROBE CABLE ASSEMBLY	BP	

© ALABAMA SPECIALTY PRODUCTS INC. 2001

Metal Samples
 152 METAL SAMPLES RD,
 MUNFORD, AL 36268
 PHONE: (256)-358-4202
 FAX: (256)-358-4515

A DIVISION OF ALABAMA SPECIALTY PRODUCTS, INC.

ENGINEERED BY BP	DRAWN BY EAN	CHECKED BY SAK	DATE 04/15/20
TITLE Control Drawing-MS26X0E/ MS29X0E ER Transmitter			GC BY LWB
SCALE	SHT. NO.	TOT. NO.	DWG. NO.
	1	1	EXWDB-000078
REV.	B		